

CHOP-CHECK STYLE STAINLESS STEEL LOWER PUMP ENDS

Also covers K1756TXXXXXX service kits



**READ THIS MANUAL CAREFULLY BEFORE INSTALLING,
OPERATING OR SERVICING THIS EQUIPMENT.**

It is the responsibility of the employer to place this information in the hands of the operator. Keep for future reference.

SERVICE KITS

- Use only genuine ARO® replacement parts to assure compatible pressure rating and longest service life.
- **K1756TXXXXXX** for general repair of **1756TXXXXXX** lower pump ends.

GENERAL DESCRIPTION

⚠ WARNING DO NOT EXCEED MAXIMUM OPERATING PRESSURE AS INDICATED ON PUMP MODEL PLATE.

⚠ WARNING REFER TO GENERAL INFORMATION SHEET FOR ADDITIONAL SAFETY PRECAUTIONS AND IMPORTANT INFORMATION.

- This manual only covers the lower pump section. It is one of four documents which support an ARO pump. Replacement copies of these forms are available upon request.
 - Pump Model Operator's Manual.
 - General Information for Air Operated or Hydraulically Operated Pumps.
 - Lower Pump End Operator's Manual.
 - Air or Hydraulic Motor Operator's Manual.
- The chop-check design provides for easy priming of the lower foot valve. The double acting feature is standard in all ARO industrial pumps. Material is delivered to the pump discharge outlet on both the up and down stroke.

MAINTENANCE

The air / hydraulic motor is completely separate from the lower pump end. This helps to keep the motor from being contaminated by the material being pumped. Periodically, flush entire pump system with a solvent that is compatible with the material being pumped.

Keep solvent cup filled with this compatible solvent. This will keep material from drying on the piston rod, which would drag thru the packings, ruin them and eventually scour the piston rod.

Provide a clean work surface to protect sensitive internal moving parts from contamination from dirt and foreign matter during disassembly and reassembly.

Before reassembling, lubricate parts as required. When assembling "O" rings, or parts adjacent to "O" rings, exercise care to prevent damage to "O" rings and "O" ring groove surface.

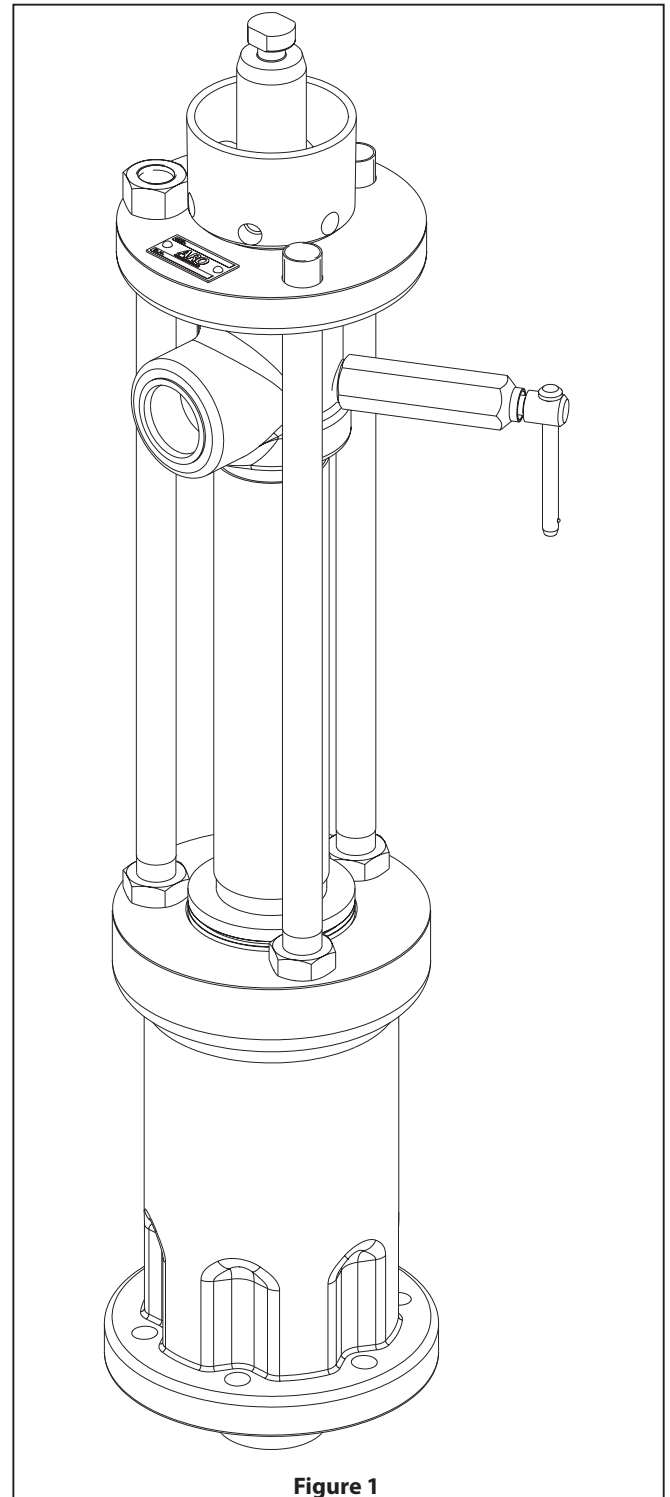

Figure 1

LOWER PUMP END DESCRIPTION CHART

	1756	T	X	X	X	X	X	X
Inside Diameter of Pump Cylinder								
1756 - 1.756" ID								
Check Type / Wetted Material								
T - Primer Piston, Stainless Steel								
Container Suitability								
1 - Remote mounting								
Inlet / Outlet Thread Type								
1 - SAE Thread								
Upper Packing Material								
F - UHMW-PE								
K - Glass Filled PTFE								
R - Glass Filled PTFE / UHMW-PE Staggered								
S - Virgin PTFE								
Lower Packing Material								
F - UHMW-PE								
K - Glass Filled PTFE								
S - Virgin PTFE								
Spring Type / Solvent Cup								
4 - Multiple wave spring								
Plunger Type								
7 - Hardened stainless steel with hard chrome plating								
G - Hardened stainless steel with hard chrome plating (button type, for large motors)								

LOWER PUMP DISASSEMBLY

NOTE: All threads are right hand.

1. Remove the (6) pump body from the (9) suction tube by sliding it off of the three (10) tie rods.
2. Remove the (7) O-ring from inside of pump body.
3. Remove the three (10) tie rods.
4. Pull the (9) suction tube off of the middle packing and valve section and out of (25) check stop.
5. Push the (26) plunger rod down to expose the primer components.
6. Remove the (33) lock nut, (32) primer button and (31) primer plate from the (30) primer rod.
7. Pull up on the (26) rod and remove the middle packing, valve section and (30) primer rod from the (15) pressure chamber body.
8. Remove the (7) O-ring from the (25) check stop.
9. Using a flat bladed screwdriver to pry on the slot in the (25) check stop, remove the (25) check stop, (21) check, (22) seat and two (23) "O" rings from the (15) pressure chamber body.
10. Remove the (24) "O" ring from the (25) check stop.
11. Using a retaining ring pliers, remove the (37) retaining ring from the (21) check, allowing removal of the (65) "U" cup packing.
12. Using the wrench flats provided, unthread and remove the (30) primer rod from the (34) valve rod and unthread and remove the (34) valve rod from the (26) plunger rod.
CAUTION: Be careful not to mar or damage the surfaces of these rods.
13. Slide the middle packing assembly off of the (34) valve rod.
14. Clamp the (28) seat in a vise and remove the (36) valve seat nut, allowing removal of the middle packing components.
15. Remove the (1) solvent cup assembly from the (6) pump body, allowing removal of the upper packing components.

LOWER PUMP REASSEMBLY

NOTE: Inspect and replace old parts with new parts as necessary. Look for deep scratches on metallic surfaces. Replace all "O" rings upon reassembly. Lubricate all threads upon reassembly. Refer to sealant and torque notes on page 3.

1. Assemble the (65) "U" cup packing into the (21) check, securing with the (37) retaining ring.
2. Assemble the (54) female packing washer, (55) "V" packings, (57) male packing washer and (47) wave spring to the (28) seat, securing with the (36) valve seat nut (refer to page 3).
3. Slide the (21) check (beveled end first) onto the end of the (30) primer rod opposite the wrench flats (refer to page 3).
4. Thread the (30) primer rod into the (34) valve rod and tighten.
5. Assemble the (24) "O" ring to the groove in the (25) check stop.
6. Slide the (25) check stop onto the (34) valve rod and (30) primer rod assembly and fit over the (21) check.
7. Slide the (28) seat and middle packing assembly over the (34) valve rod (beveled end first).
8. Thread the (34) valve rod to the (26) plunger rod and tighten, using the wrench flats provided.
9. Assemble one (23) "O" ring, the (22) seat (large OD chamfer facing down) and the other (23) "O" ring into the (15) pressure chamber body.

PARTS LIST / 1756TXXXXX

Item	Description (size)	Qty	Part No.	[Mtl]
1	Solvent Cup Assembly	(1)	97899	[SH]
4	Rod (not shown, used to adjust item 1)	(1)	93456-1	[C]
6	Pump Body	(1)	97900	[SH]
✓ 7	O-Ring	(2)	98013	[T]
8	Valve Assembly	(1)	62113	[SS]
9	Suction Tube	(1)	97901	[SH]
10	Tie Rod	(3)	91725	[C]
11	Nut (5/8" - 18)	(3)	Y11-110-N	[C]
15	Pressure Chamber Body	(1)	97887	[SH]
21	Check	(1)	97886	[SH]
22	Seat	(1)	97889	[SH]
✓ 23	"O" Ring (3/32" x 2-5/8" OD)	(2)	Y328-143	[T]
✓ 24	"O" Ring (1/8" x 2-5/8" OD)	(1)	97895	[FEP]
25	Check Stop	(1)	97907	[SH]
26	Plunger Rod (1756TXXXXX7)	(1)	91731-1	[SH]
	(1756TXXXXXG)	(1)	94923	[SH]
28	Seat	(1)	97905	[SH]
30	Primer Rod	(1)	97891	[SH]
31	Primer Plate	(1)	93597-1	[SS]
32	Primer Button	(1)	93596-1	[SS]
33	Lock Nut (7/16" - 20)	(1)	97897	[SS]
34	Valve Rod (1756TXXXXX7)	(1)	97903	[SH]
	(1756TXXXXXG)	(1)	92228-1	[SH]

MATERIAL CODE

[B] = Nitrile	[GFT] = Glass filled PTFE
[Br] = Brass	[L] = Leather
[C] = Carbon Steel	[PPS] = Polyphenylene sulfide
[Co] = Copper	[SH] = Hard Stainless Steel
[D] = Acetal	[SS] = Stainless Steel
[DI] = Ductile Iron	[T] = PTFE
[FEP] = Encapsulated O-rings	[UH] = UHMW-PE

10. Assemble the (26) plunger rod and components into the (15) pressure chamber body with the (30) primer rod going in first. Slide the (25) check stop into place in the (25) pressure chamber body.
11. Place the (7) O-ring in the (25) check stop.
12. Lubricate the middle packing assembly and the inside of the (9) suction tube and carefully slide the suction tube over the (26) plunger rod and middle packing assembly and into the (25) check stop.
13. Install the three (10) tie rods.
14. Place the (7) O-ring from bottom of pump body.
NOTE: Apply a small amount of grease on the O-ring to help keep it in place.
15. Assemble the (6) pump body over the (26) plunger rod and onto the (10) tie rods. Seat the (9) suction tube into the (6) pump body.
16. Assemble the (43) wave spring, (53) male packing washer, (51 and 52) "V" packings and (115) backup onto the (26) plunger rod and into the (6) pump body (refer to page 3).
17. Install the (1) solvent cup assembly and hand tighten.
18. Push the (26) plunger rod down to expose the (30) primer rod at the bottom of the pump. Assemble the (31) primer plate and the (32) primer button (beveled edge away from the pump) onto the (30) primer rod, securing with the (33) lock nut.

Item	Description (size)	Qty	Part No.	[Mtl]
36	Valve Seat Nut	(1)	97904	[SH]
✓ 37	Retaining Ring	(1)	97894	[SS]
39	Seat (1756TXXXXXG)	(1)	98012	[SH]
43	Wave Spring	(1)	98014	[SS]
✓ 47	Bowed Washer	(1)	97906	[SS]
✓ 51	"V" Packing (1756TXXEXXX)	(5)	93454-4	[UH]
	(1756TXXKXXX)	(5)	93454-2	[GFT]
	(1756TXXRXXX)	(3)	93454-2	[GFT]
	(1756TXXSXXX)	(5)	93454-5	[T]
✓ 52	"V" Packing (1756TXXRXXX)	(2)	93454-4	[UH]
✓ 53	Male Packing Washer	(1)	91724	[PPS]
✓ 54	Female Packing Washer	(1)	90322	[SS]
✓ 55	"V" Packing (1756TXXXEXX)	(4)	93455-4	[UH]
	(1756TXXXKXX)	(4)	93455-2	[GFT]
	(1756TXXXSXX)	(4)	93455-5	[T]
✓ 57	Male Packing Washer	(1)	90305	[PPS]
✓ 65	"U" Cup (1756TXXXEXX, 1756TXXXKXX)	(1)	90911	[GFT]
	(1756TXXXSXX)	(1)	98015	[T]
115	Backup	(1)	98016	[PPS]
✓	Items included in Service Kit		K1756TXXXXXX	

19. Push up on the (30) primer rod until the primer rod is inside the (15) pressure chamber body, then tighten the (1) solvent cup assembly.

TROUBLESHOOTING

No material at outlet (pump continually cycles).

- Check material supply. Disconnect or shut off the air supply and replenish the material, reconnect.

Material on one stroke only (fast down stroke).

- The (21) check may not be seating in the (22) seat (see lower pump disassembly). Remove the check from the seat, clean and inspect the check and seat area. If the check or seat is damaged, replace.

Material on one stroke only (fast upstroke).

- The (34) valve rod may not be seating in the (28) seat (see lower pump disassembly). Remove the valve rod from the seat, clean and inspect the valve rod and seat area. If the valve rod or seat is damaged, replace. Check for worn or damaged packings. Replace the packings as necessary.

Material leakage out of the solvent cup or material appears on the pump plunger rod.

- Relieve the pressure in the pump and tighten the solvent cup until leakage discontinues. If this procedure does not aid in stopping the leakage problem, the upper packings may be worn (see lower pump disassembly). Replace the packings as necessary.

PARTS LIST / 1756TXXXXX

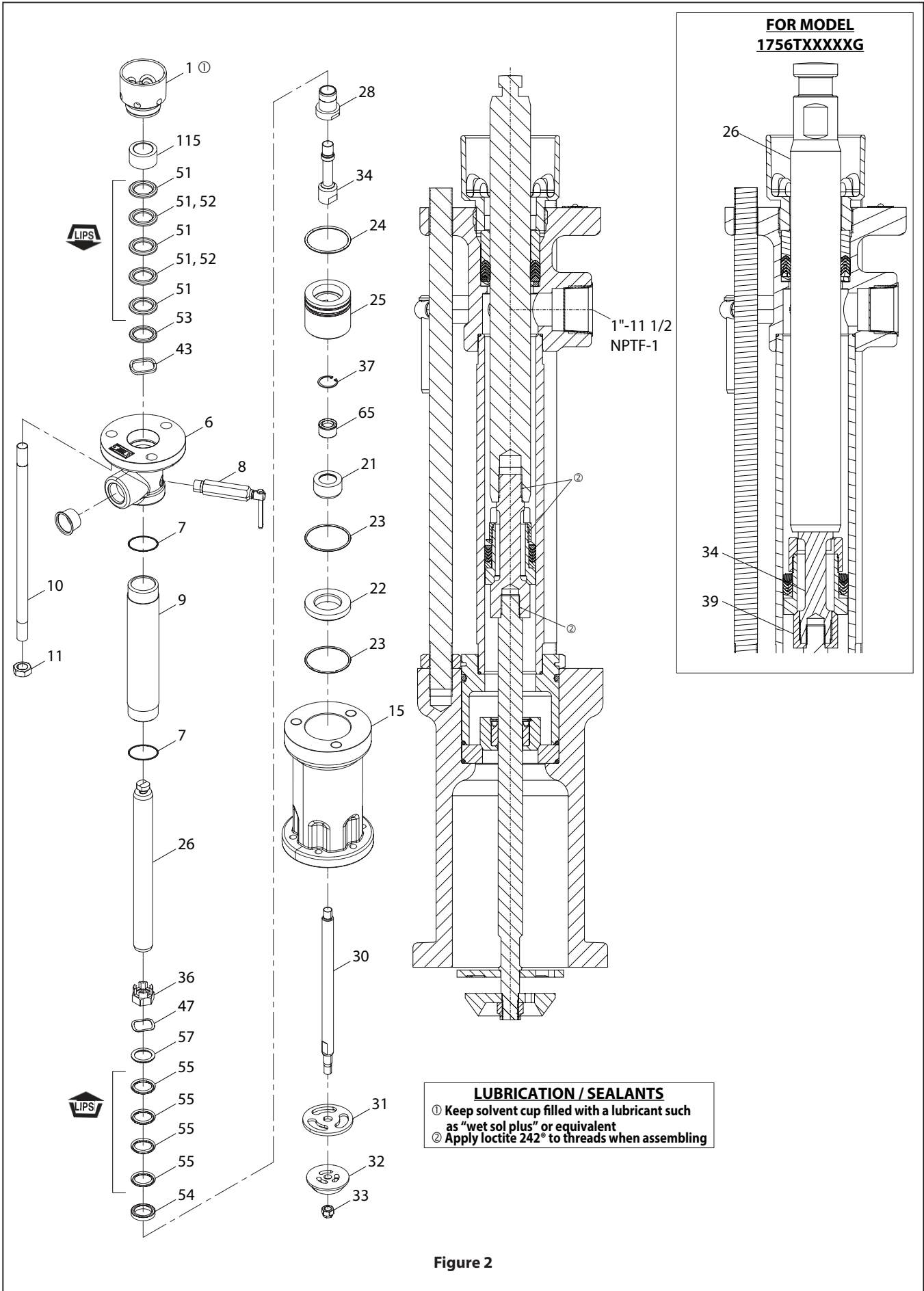

Figure 2