

OPERATOR'S MANUAL

650934-X-C

INCLUDING: SPECIFICATIONS, SERVICE KITS, GENERAL INFORMATION, TROUBLESHOOTING.

INCLUDE MANUALS: 66243-X-B Lower Pump End (pn 97999-828), 67147-B Hydraulic Motor (pn 97999-1219) & S-632 General Information Manual (pn 97999-624)

RELEASED: 9-29-00

REVISED: 11-10-06

(REV. C)

2.062 SQ." HYDRAULIC MOTOR
2:1 RATIO
6" STROKE

650934-XX3-C

CHOP-CHECK PUMP SERIES

CARBON STEEL



**READ THIS MANUAL CAREFULLY BEFORE INSTALLING,
OPERATING OR SERVICING THIS EQUIPMENT.**

It is the responsibility of the employer to place this information in the hands of the operator. Keep for future reference.

SERVICE KITS

- Use only genuine ARO® replacement parts to assure compatible pressure rating and longest service life.
- **637449** for repair of hydraulic motor section.
- **637071-X43-B** for repair of lower pump section. Refer to the chart on page 2 for description of -XXX options.

SPECIFICATIONS

Model Series (refer to option chart)	650934-XX3-C
Type	Hydraulically Operated, Chop-Check
Ratio	2:1
Hydraulic Motor	67147-B
Motor Repair Kit	637449
Motor Size	2.062 sq." (13.3 sq. cm)
Stroke	6" (15.2 cm)
Hydraulic Inlet (female)	3/8 - 18 N.P.T.F. - 2
Hydraulic Return (female)	1/2 - 14 N.P.T.F. - 2
Lower Pump End Series	66243-XX3-B
Lower Pump Repair Kit	637071-X43-B
Material Inlet	N/A
Material Outlet (female)	1 - 11-1/2 N.P.T.F. - 1
Weight	62.4 lbs (28.3 kgs)

PERFORMANCE

Hydraulic Inlet Pressure Range	50 - 1200 p.s.i. (3.4 - 83 bar)
Fluid Pressure Range	100 - 2400 p.s.i. (6.9 - 165.5 bar)
Required H-power @ 50 c.p.m.	3.2 @ 1200 (83 bar)
Hydraulic flow required @ 50 c.p.m.	4.9 g.p.m. (18.5 l.p.m.)
Maximum rec'd Cycles / Minute	50
Displacement In ³ Per Cycle	12.503
Volume / Cycle	6.9 oz. (205 ml)
Cycles Per Gallon	18.5
Flow @ 50 Cycles / Minute	2.7 g.p.m. (10.2 l.p.m.)
Noise Level	N/A
Maximum Temperature Limit	130° F (54° C)

PUMP DATA

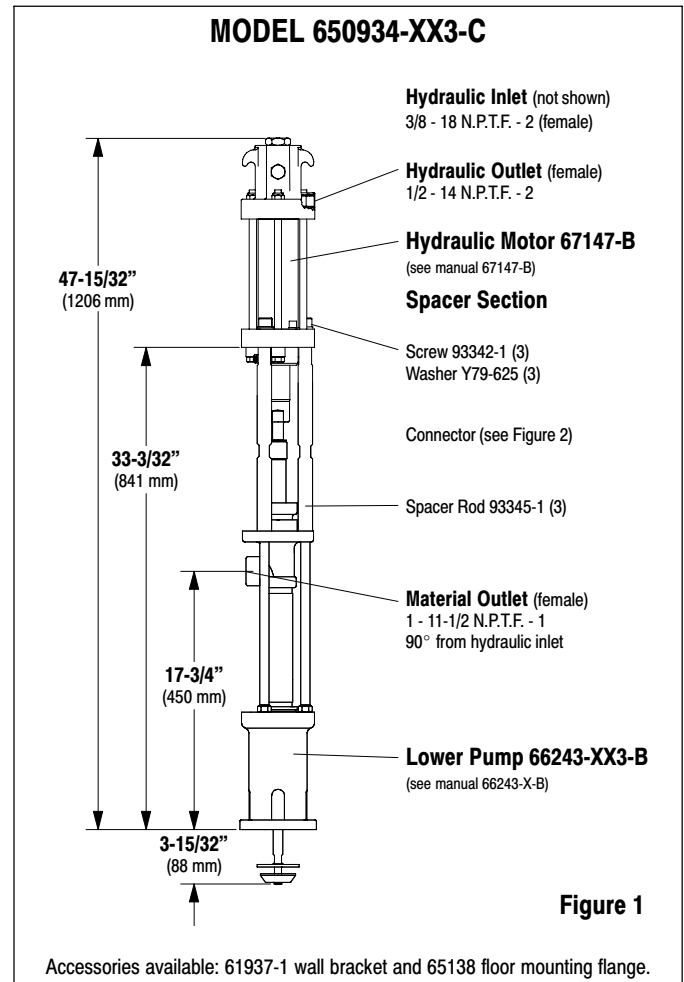

Figure 1

IMPORTANT

This is one of the four documents which support the pump. Replacement copies of these forms are available upon request.

- 650934-X-C Model Operator's Manual (pn 97999-835)
- S-632 General Information - Industrial Piston Pumps (pn 97999-624)
- 66243-X-B Lower Pump End Operator's Manual (pn 97999-828)
- 67147-B Hydraulic Motor Operator's Manual (pn 97999-1219)

PUMP OPTION DESCRIPTION CHART

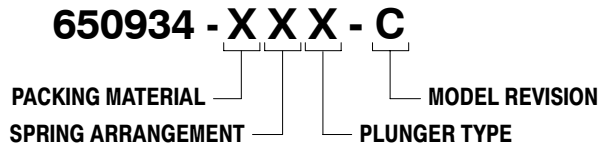

PACKING MATERIAL (packings are upper and lower unless noted)

- 3 Glass filled Teflon
- C UHMW-PE
- G UHMW-PE / Leather staggered
- P UHMW-PE / Teflon staggered (upper) / UHMW-PE (lower)
- R Teflon / UHMW-PE staggered (upper) / Teflon (lower)

SPRING ARRANGEMENT

- 4 Multiple wave spring
- 9 Multiple wave spring with alternate solvent cup
- B Multiple wave spring with 2 piece spacer

PLUNGER TYPE

- 3 Hardened stainless steel with hard chrome plating

GENERAL DESCRIPTION

⚠ WARNING HAZARDOUS PRESSURE. Do not exceed maximum operating pressure of 2400 p.s.i. (165.5 bar) at 1200 p.s.i. (82.8 bar) inlet hydraulic pressure.

PUMP RATIO X INLET PRESSURE TO PUMP MOTOR	=	MAXIMUM PUMP FLUID PRESSURE
<p>Pump ratio is an expression of the relationship between the pump motor area and the lower pump end area. EXAMPLE: When 150 p.s.i. (10.3 bar) inlet pressure is supplied to the motor of a 5:1 ratio pump it will develop a maximum of 750 p.s.i. (52 bar) fluid pressure (at no flow) - as the fluid control is opened, the flow rate will increase as the motor cycle rate increases to keep up with the demand.</p>		

⚠ WARNING Refer to general information sheet for additional safety precautions and important information.

- The chop-check pumps are primarily designed for the pumping of heavy viscous material with or without fibrous content. The models can be used with a gravity feed single post lift as a topper type assembly or with a two post lift as a force feed type assembly. The lower pump is designed for easy priming and the double acting feature is standard in all ARO industrial pumps. Material is delivered to the pump discharge outlet on both the up and down stroke.
- The motor is connected to the lower pump end by a spacer section. This allows for lubrication of the upper packing gland and prevents motor contamination because of normal wear and eventual leakage through the material packing gland. Be sure the solvent cup is adequately filled with lubricant to protect the upper packings and insure longest service life.

TROUBLE SHOOTING

Pump problems can occur in either the hydraulic motor section or the lower pump end section. Use these basic guidelines to help determine which section is affected.

If the pump will not cycle.

- Be certain to first check for non-pump problems including kinked, restrictive or plugged inlet / outlet hose or dispensing device. Depressurize the pump system and clean out any obstructions in the inlet / outlet material lines.
- Refer to the motor manual for trouble shooting if the pump does not cycle and / or hydraulic fluid leaks from the hydraulic motor.

If the pump cycles but does not deliver material.

- Refer to the lower pump end manual for further trouble shooting.

PUMP CONNECTION - UPPER / LOWER

NOTE: All threads are right hand.

1. Lay the pump assembly on a workbench.
2. Remove the three screws and washers from the three spacer rods (see figure 1).
3. Pull the hydraulic motor from the lower pump end until motor piston rod is in the "down" position and lower pump end rod is in "up" position.
4. Using e-ring pliers, slide the retaining ring up far enough to allow the sleeve to move upward and release the two connectors (see figure 2).

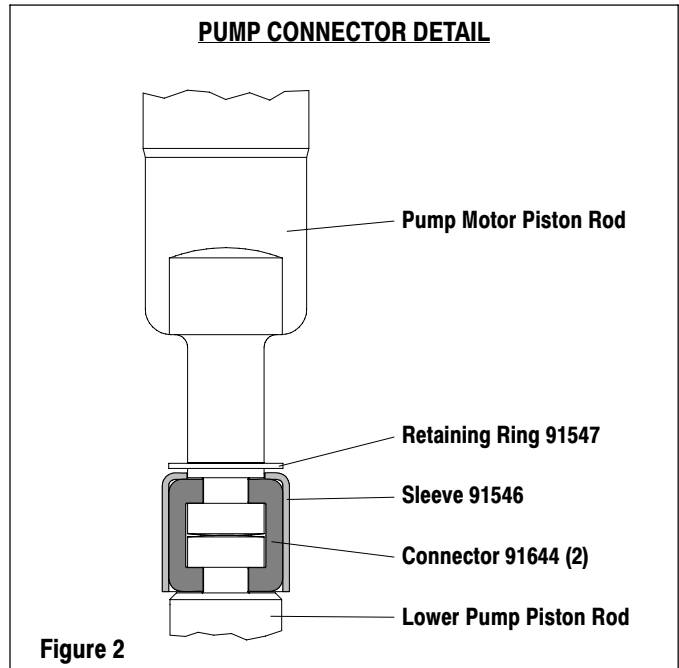

REASSEMBLY

1. Align the pump motor with the lower pump end.
2. Install the two connectors and retain with the sleeve, slide the retaining ring back into position.
3. Reinstall the spacer rods to the pump motor.
4. Bring the motor and lower pump together and retain with the three screws and washers.

NOTE: If 93345-1 (3) spacer rods are removed from lower end to service lower end then torque evenly to 60 - 90 ft lbs (81.3 - 122.0 Nm).