

CHOP-CHECK STYLE LOWER PUMP ENDS

Also covers 637128-XX4-B service kits



**READ THIS MANUAL CAREFULLY BEFORE INSTALLING,
OPERATING OR SERVICING THIS EQUIPMENT.**

It is the responsibility of the employer to place this information in the hands of the operator. Keep for future reference.

SERVICE KITS

Use only genuine ARO® replacement parts to assure compatible pressure rating and longest service life.
637128-XX4-B for general repair of 66236-XXX-B lower pump ends.

GENERAL DESCRIPTION

WARNING DO NOT EXCEED MAXIMUM OPERATING PRESSURE AS INDICATED ON PUMP MODEL PLATE.

WARNING REFER TO GENERAL INFORMATION SHEET FOR ADDITIONAL SAFETY PRECAUTIONS AND IMPORTANT INFORMATION.

- This manual covers the lower pump section. It is one of four documents which support an ARO pump. Replacement copies of these forms are available upon request.
 - 650XXX-X Pump Model Operator's Manual.
 - General Information for Air Operated or Hydraulically Operated Pumps.
 - Lower Pump End Operator's Manual.
 - Air or Hydraulic Motor Operator's Manual.
- The chop-check design provides for easy priming of the lower foot valve. The double acting feature is standard in all ARO industrial pumps. Material is delivered to the pump discharge outlet on both the up and down stroke.

MAINTENANCE

The air / hydraulic motor is completely separate from the lower pump end. This helps to keep the motor from being contaminated by the material being pumped. Periodically, flush entire pump system with a solvent that is compatible with the material being pumped.

Keep solvent cup filled with this compatible solvent. This will keep material from drying on the piston rod, which would drag thru the packings, ruin them and eventually scour the piston rod.

Provide a clean work surface to protect sensitive internal moving parts from contamination from dirt and foreign matter during disassembly and reassembly.

Before reassembling, lubricate parts as required. When assembling "O" rings, or parts adjacent to "O" rings, exercise care to prevent damage to "O" rings and "O" ring groove surface.

LOWER PUMP END DESCRIPTION CHART

66236 - X X X - B

Packing Material

- 3 - Glass filled PTFE (upper and lower)
- C - UHMW-PE (upper and lower)
- F - UHMW-PE / Leather staggered (upper)
 - UHMW-PE (lower)
- J - Polyurethane (upper)
 - UHMW-PE (lower)
- P - UHMW-PE / Glass filled PTFE staggered (upper)
 - UHMW-PE (lower)
- R - Glass filled PTFE / UHMW-PE staggered (upper)
 - Glass filled PTFE (lower)

Spring Arrangement (Service kit spring designation)

- 3 - No spring (3)
- 4 - Multiple wave spring (4)
- 8 - No spring with alternate solvent cup (3)
- 9 - Multiple wave spring with alternate solvent cup (4)

Plunger Type

- 4 - Carbon steel with hard chrome plating (threaded)
- E - Carbon steel with hard chrome plating (button type)
- H - Carbon steel with hard chrome plating (button type, small motor)

Service Kit Selection

66236 - X X X - B
637128 - X X 4 - B
Example: Lower Pump End # 66236-C44-B
Service Kit # 637128-C44-B

TROUBLE SHOOTING

No material at outlet (pump continually cycles).

- Check material supply. Disconnect or shut off the air supply and replenish the material, reconnect.

Material on one stroke only (fast downstroke).

- The (21) foot valve body may not be seating in the (22) check valve seat (see lower pump disassembly). Remove the (21) foot valve body from the (22) check valve seat, clean and inspect the check valve seat area. If the foot valve or seat is damaged, replace.

Material on one stroke only (fast upstroke).

- Check for worn or damaged packings and seals. Replace the packings and seals as necessary.

Material leakage out of the solvent cup or material appears on the pump plunger rod.

- Relieve the pressure in the pump and tighten the solvent cup until leakage discontinues. If this procedure does not aid in stopping the leakage problem, the upper packings may be worn (see lower pump disassembly). Replace the packings as necessary.

PARTS LIST / 66236-XXX-B

Item	Description (size)	(Qty)	Part No.	Mtl
1	Solvent Cup (66236-X3X-B, 66236-X4X-B)	(1)	92689	[C]
	(66236-X8X-B, 66236-X9X-B)	(1)	95055	[C]
2	Packing Nut	(1)	99925	[C]
3	"O" Ring (1/16" x 3" o.d.)	(1)	Y325-40	[B]
5	Bushing	(1)	99876	[D]
6	Outlet Body	(1)	93865	[DI]
✓ 7	Gasket	(3)	92672	[Co]
8	Valve Assembly (see figure 2)	(1)	62113	[SS]
9	Tube	(1)	92673	[C]
10	Stud	(3)	79107	[C]
12	Nut (1" - 14)	(3)	Y11-16-C	[C]
13	Pipe Plug (3/8 - 18 N.P.T. x 13/32")	(1)	Y227-4	[C]
15	Pressure Chamber Body	(1)	92684-B	[I]
17	Lock Washer (1")	(3)	Y14-100-C	[C]
19	Stop Assembly	(1)	61899-B	[C]
21	Foot Valve Body	(1)	92682	[SH]
22	Check Valve Seat	(1)	96830	[SH]
26	Plunger Assembly (66236-XX4-B)	(1)	66118	[PC]
	(66236-XXE-B)	(1)	67202	[PC]
	(66236-XXH-B)	(1)	67202-1	[PC]
27	Valve	(1)	99944	[SH]
28	Valve Seat	(1)	92681	[SH]
30	Primer Rod	(1)	91719	[SH]
31	Primer Plate	(1)	93599-1	[SS]
32	Primer Button	(1)	93598-1	[SS]
33	Lock Nut (7/16" - 20)	(1)	Y171-7-C	[C]

Item	Description (size)	(Qty)	Part No.	Mtl
36	Valve Seat Nut	(1)	92675	[C]
✓ 37	Retaining Ring (1.136" o.d.)	(1)	Y147-102	[C]
✓ 38	Gasket	(1)	92669	[Ny]
40	Dowel Pin (3/8" o.d. x 1")	(3)	Y148-58	[C]
43	Wave Spring (66236-X4X-B, 66236-X9X-B)	(1)	99851	[SH]
46	Washer	(6)	90529-1	[C]
✓ 47	Spring Washer (66236-3XX-B, 66236-RXX-B)	(1)	92676	[C]
50	Packing Washer (66236-X4X-B, 66236-X9X-B)	(1)	92664	[D]
✓ 51	"V" Packing (66236-3XX-B, 66236-RXX-B)	(3)	93672-2	[GFT]
	(66236-CXX-B, 66236-FXX-B, 66236-PXX-B)	(3)	93672-4	[UH]
✓ 52	"V" Packing (66236-3XX-B, 66236-PXX-B)	(2)	93672-2	[GFT]
	(66236-CXX-B, 66236-RXX-B)	(2)	93672-4	[UH]
	(66236-FXX-B)	(2)	93672-1	[L]
53	Packing Washer (66236-X4X-B, 66236-X9X-B)	(1)	92667	[C]
54	Packing Washer (66236-3XX-B, 66236-RXX-B)	(1)	92680	[C]
✓ 55	"V" Packing (66236-3XX-B, 66236-RXX-B)	(3)	93680-2	[GFT]
✓ 56	"V" Packing (66236-3XX-B, 66236-RXX-B)	(2)	93680-2	[GFT]
57	Packing Washer (66236-3XX-B, 66236-RXX-B)	(1)	92679	[C]
✓ 63	Bushing (66236-X3X-B, 66236-X8X-B)	(1)	99951	[D]
✓ 64	Rod Seal (66236-JXX-B)	(1)	93676-1	[U]
✓ 65	"U" Cup Packing	(1)	90911	[GFT]
✓ 73	"W" Packing (66236-CXX-B, 66236-FXX-B, 66236-JXX-B, 66236-PXX-B)	(1)	93673-1	[UH]
✓ 74	Wiper (66236-CXX-B, 66236-FXX-B, 66236-JXX-B, 66236-PXX-B)	(1)	93675-1	[UH]
✓	Items included in Service Kit		637128-XX4-B	

NOTE: Service kit also includes two Y15-46-C cotter pins (1/8" o.d. x 1-3/4" long).

MATERIAL CODE

[B] = Nitrile	[L] = Leather
[C] = Carbon Steel	[Ny] = Nylon
[Co] = Copper	[PC] = Hard Chrome Plated Carbon Steel
[D] = Acetal	[SH] = Hardened Stainless Steel
[DI] = Ductile Iron	[SS] = Stainless Steel
[GFT] = Glass filled PTFE	[U] = Urethane
[I] = Iron	[UH] = UHMW-PE

LOWER PUMP DISASSEMBLY

NOTE: All threads are right hand.

- Remove three (12) nuts, (46) washers, (17) lock washers and (46) washers from three (10) studs.
- Remove (6) outlet body from (9) tube, (10) studs and (26) plunger assembly. Lay (6) outlet body aside.
- Remove (7) gasket from top of (9) tube.
- Remove three (10) studs.
- Remove (9) tube by pulling it off the middle packing and valve section and out of (15) pressure chamber body.
- Push (26) plunger assembly down to expose the primer assembly.
- Remove (33) lock nut, releasing (32) primer button and (31) primer plate.
- Pull (26) plunger assembly and remove middle packing, valve section and (30) primer rod from (15) pressure chamber body.
- Remove (7) gasket out of (15) pressure chamber body.
- Using a flat blade screwdriver, remove (19) stop assembly, (21) foot valve body, (7) gasket and (22) check valve seat out of (15) pressure chamber body.
- Using retaining ring pliers, remove (37) retaining ring

from (21) foot valve body, then remove (65) "U" cup packing.

- Using wrenches on flats provided, remove (30) primer rod from (27) valve. Using wrenches on flats, remove (27) valve from (26) plunger assembly. Remove three (40) dowel pins. CAUTION: Do not mar or damage the surface of these dowel pins.
- Slide the middle (55 and 56) packing assembly off (27) valve.
- Clamp (28) valve seat in a vise and remove (36) valve seat nut, then remove the middle (55 and 56) packing assembly and (47) spring washer off (28) valve seat.
- Remove (2) packing nut from (6) outlet body and remove (43) wave spring and upper (51 and 52) packing assembly.
- Remove (50) female packing washer and (53) male packing washer.

LOWER PUMP REASSEMBLY

NOTE: All threads are right hand. Grease all rubber goods and packings before placing into position (it is not necessary to grease UHMW-PE and PTFE packings).

- Assemble the upper packing into the (6) outlet body, using the desired material (see figure 1).
- Assemble (27) valve, three (40) dowel pins, (28) valve seat, middle packings and (36) valve seat nut (see figure 1).
- Assemble the (65) "U" cup packing into the (21) foot

(continued on page 4)

PARTS LIST / 66236-XXX-B

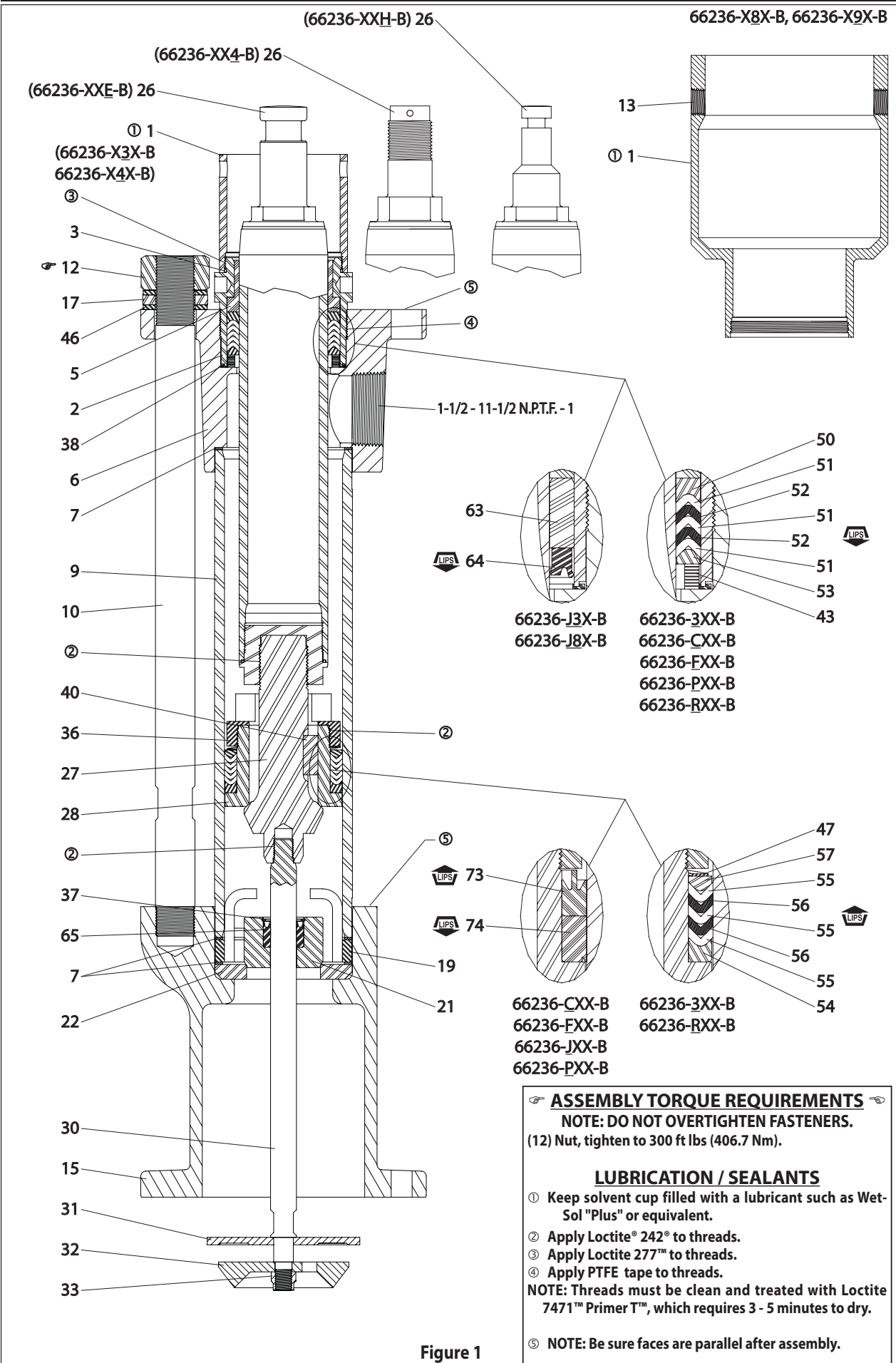

ASSEMBLY TORQUE REQUIREMENTS
 NOTE: DO NOT OVERTIGHTEN FASTENERS.
 (12) Nut, tighten to 300 ft lbs (406.7 Nm).

LUBRICATION / SEALANTS

① Keep solvent cup filled with a lubricant such as Wet-Sol "Plus" or equivalent.

② Apply Loctite® 242® to threads.

③ Apply Loctite 277™ to threads.

④ Apply PTFE tape to threads.

NOTE: Threads must be clean and treated with Loctite 7471™ Primer T™, which requires 3 - 5 minutes to dry.

⑤ NOTE: Be sure faces are parallel after assembly.

Figure 1

- valve body, securing with (37) retaining ring.
4. Place the (22) check valve seat and (7) gasket into (15) pressure chamber body.
 5. Slide (21) foot valve body onto (30) primer rod. Place this assembly into (15) pressure chamber body (see figure 1).
 6. Place (19) stop assembly and (7) gasket over (21) foot valve body and into position.
 7. Secure the (6) outlet body in a vise. Slide the female end of (26) plunger assembly through (6) outlet body.
 8. With the (6) outlet body still in a vise, apply Loctite 242 Threadlocker to threads of (27) valve and attach (27) valve to (26) plunger assembly and tighten.
 9. Lubricate the middle packings and inside of the (9) tube. Place (7) gasket in the (6) outlet body. Carefully slide (9) tube over the rod assembly, seating it in (6) outlet body.
 10. Secure (8) valve assembly into (6) outlet body.
 11. Remove the assembly from the vise.
 12. Apply Loctite 242 to the threads of (30) primer rod (see figure 1) and thread (30) primer rod into (27) valve and tighten.
 13. Slide (15) pressure chamber body over (9) tube and into position.
 14. Slide (10) studs through the holes in (6) outlet body and secure to (15) pressure chamber body.
 15. Assemble three (46) washers, (17) lock washers, (46) washers to (10) studs, securing with three (12) nuts. NOTE: Tighten (12) nuts to 300 ft lbs (406.7 Nm). NOTE: Be sure faces of (6) outlet body and (15) pressure chamber body are parallel after assembly.
 16. To install (32) primer button, push down on (26) plunger assembly to expose (30) primer rod out the bottom of (15) pressure chamber body. Assemble (31) primer plate and (32) primer button to (30) primer rod, securing with (33) lock nut.

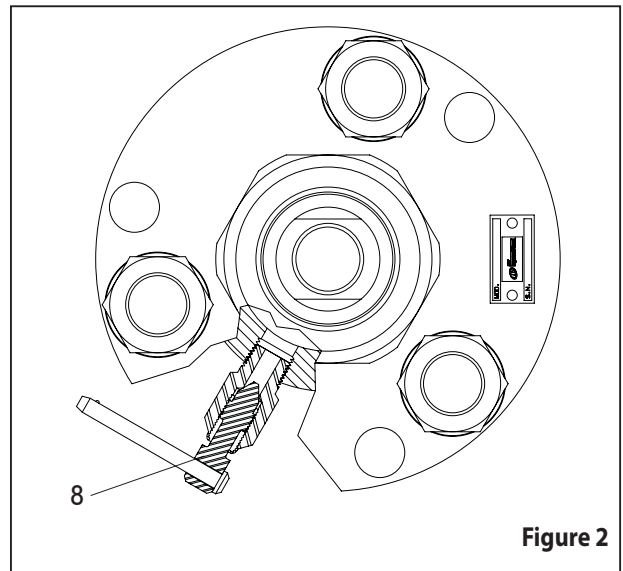

Figure 2

- ARO® is a registered trademark of Ingersoll-Rand Company •
- Loctite® and 242® are registered trademarks of Henkel Loctite Corporation •
- 277™, 7471™ and Primer T™ are trademarks of Henkel Loctite Corporation •